**Dimensions**

MODEL	A	B	C
SHm-180F	184	140	373
SHm-250F	184	140	393
SHm-450F	251	200	463
SHm-750F	251	200	491
SHm-1100F	251	200	523
SHm-1500F	251	200	535

**Application**

- ◆ Wastewater drainage in factories, construction sites and commercial facilities
- ◆ Drainage system in municipal sewage treatment plants
- ◆ Drainage station in residential quarters
- ◆ Municipal projects
- ◆ Methane pools and field irrigation in countryside

**Pump**

- ◆ Max: immersion depth: 5m
- ◆ Max: liquid temperature: +40°C
- ◆ Liquid PH value: 5-9
- ◆ Liquid kinematic viscosity:  $7 \times 10^{-6} \sim 23 \times 10^{-6} \text{m}^2/\text{s}$
- ◆ Max. liquid density:  $1.2 \times 10^3 \text{kg}/\text{m}^3$

**Motor**

- ◆ Copper winding
- ◆ Built-in thermal protector
- ◆ Stainless steel welded shaft
- ◆ Insulation class :B
- ◆ Protection class:IPX8

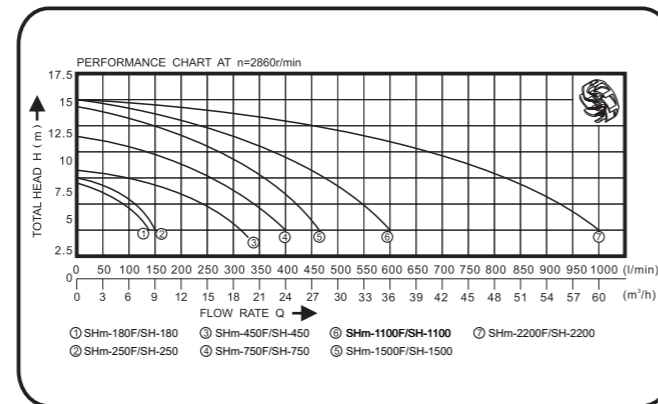
**Technical Table**

Model	Power (kw)	Outlet Diameter (mm)	Voltage/ Frequency (V/Hz)	Max. Flow (l/min)	Max. Head (m)	Max. Diameter of Particle (mm)	G.W. (kg)	Dimensions (cm)
SHm-180F/SH-180	0.18	32	220V/380V/50HZ	133	7	25	9.6	22.5X18.5X42.0
SHm-250F/SH-250	0.25	32	220V/380V/50HZ	150	7.5	25	10.6	22.5X18.5X44.0
SHm-180F/SH-450	0.45	50	220V/380V/50HZ	333	8.5	40	20	30.0X24.5X53.0
SHm-750F/SH-750	0.75	50	220V/380V/50HZ	400	11.5	40	22.6	30.0X24.5X56.5
SHm-1100F/SH-1100	1.1	50	220V/380V/50HZ	466	14.5	40	23.6	30.0X24.5X57.5
SHm-1500F/SH-1500	1.5	50	220V/380V/50HZ	600	15	40	32.8	34.5X30.0X66.5
SHm-2200F/SH-2200	2.2	100	220V/380V/50HZ	1000	15	20	38	39.0X28.0X60.0

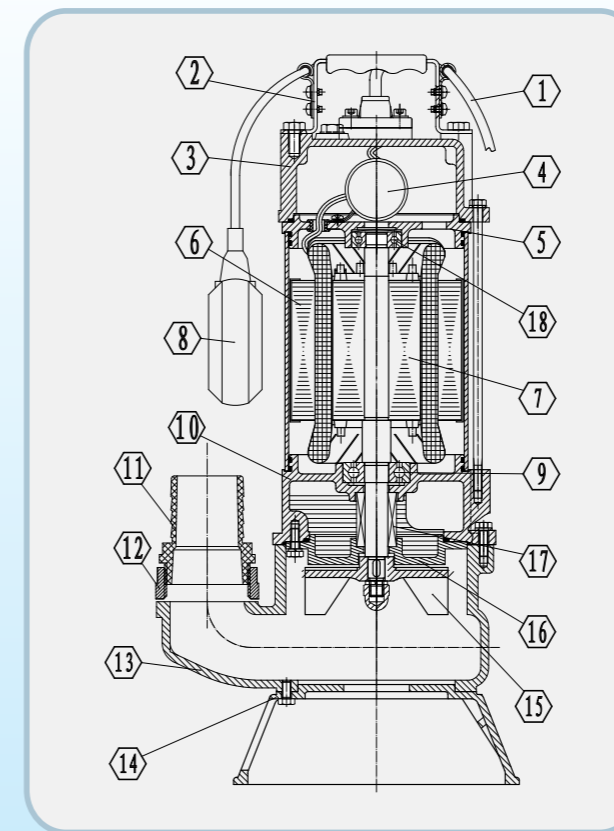

NO.	NAME	MATERIAL/SPEC.
1	Cable components	
2	Handle	AISI201
3	Capacitor Cover	HT200
4	Capacitor	
5	Upper cover	HT200
6	Motor	AISI201(Motor casing)
7	Rotor	AISI304
8	Float Switch (optional)	
9	Bearing(DGBB)	
10	Connecting Base	HT200
11	Out-let connector	ABS
12	Flange connector	HT200
13	Pump Body	HT200
14	Base plate	HT200
15	Impeller	HT200
16	Cylinder Cover	HT200
17	Double Mechanical Seal	Ceramic/Graphite
18	Bearing(DGBB)	